

Q-Step - Smart-Step

41.0343 - Smart-Step for Sprinter 18- RWD

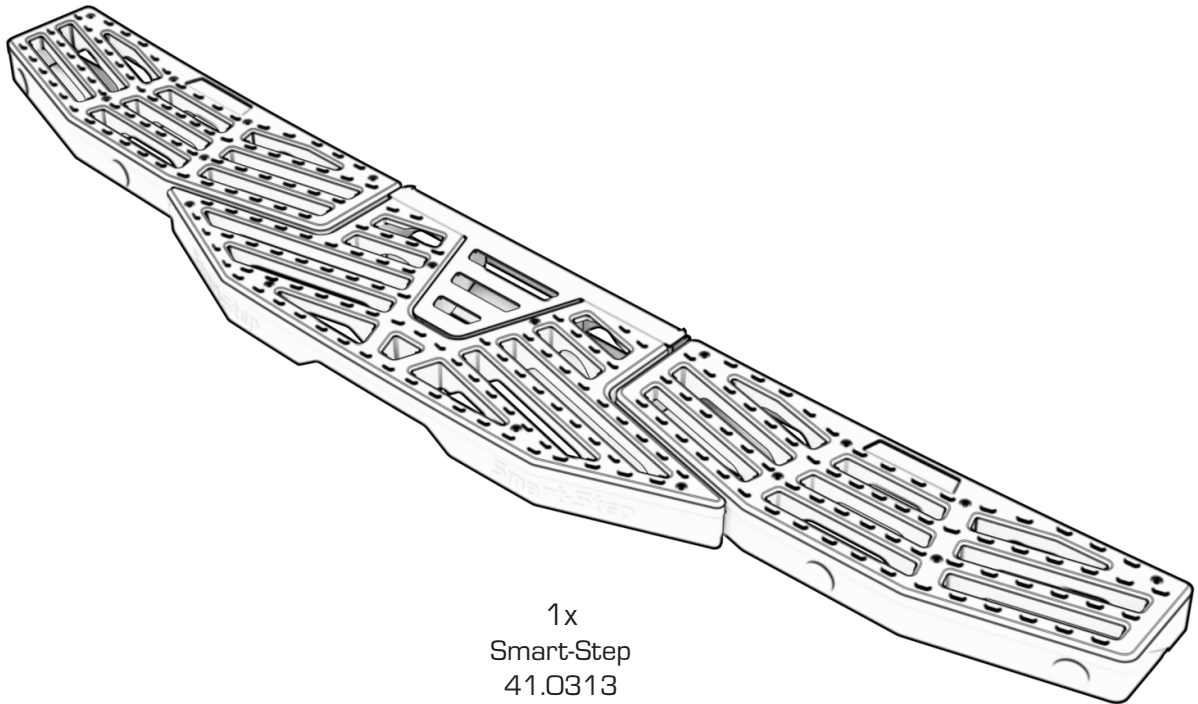

1x
Smart-Step
41.0313

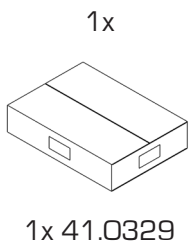

	4x	4x	8x	4x
	M12x110 El. Galv. 20.0111	M12 El. Galv. 20.0175	M12 (x36) El. Galv. 20.0441	M12 El. Galv. 20.0211
1x	1x	4x	8x	4x
Support Driver side	Support Passenger side	M10x45 El. Galv. 20.0591	M10 El. Galv. 20.0185	M10 El. Galv. 20.0563

Carefully checked by: _____
Packaging Date: _____

17 - M10
T54 Nm
24 - M12
T93 Nm



Aan alle technische tekeningen kunnen geen rechten worden ontleend, maatvoering kan afwijken van de realiteit.
No rights can be derived from these technical drawings, sizes may differ from reality.
Aucuns droits ne peuvent être dérivés de tous les dessins, dimensions peuvent différer de la réalité.
Alle technischen Zeichnungen können keine Rechte abgeleitet werden, Abmessungen können von der Realität abweichen.

Manual nr: A-01

1 Mount supports on chassis

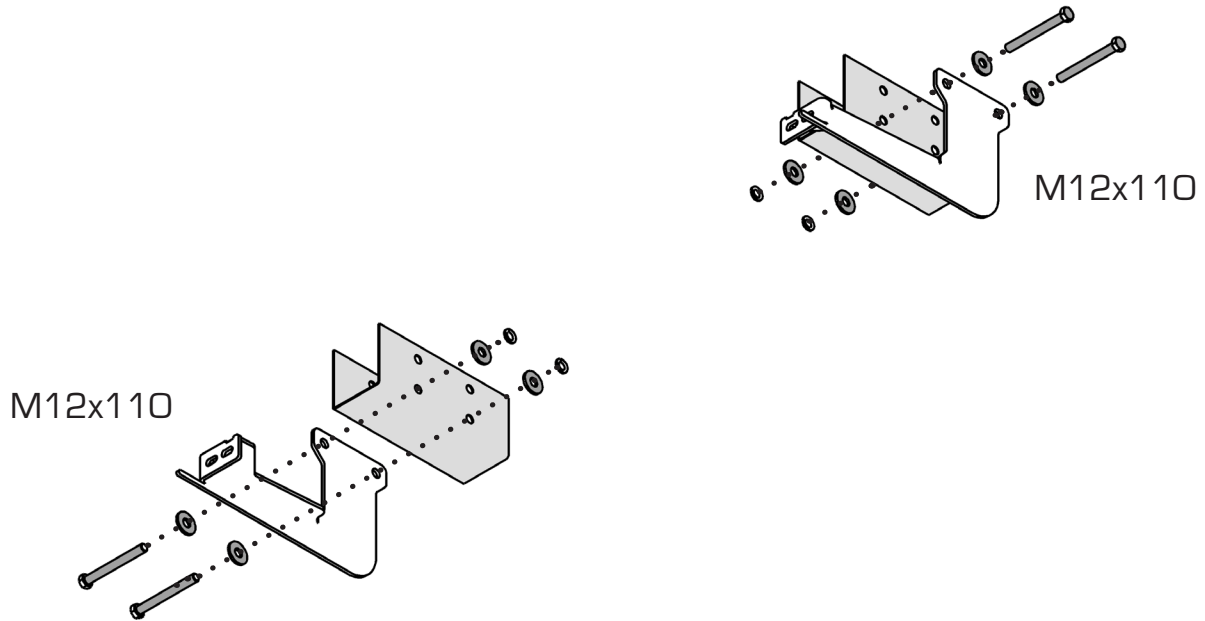

2 Mount Smart-Step to supports

