

(D) Achtung: Montageanweisungen für Aluminium-Lastenträger. **(GB) Attention:** Mounting instructions for aluminium bar carriers. **(F) Attention:** Notices de montage pour barres de portage en aluminium. **(E) Atencion:** Instrucciones de montaje para barras portatodo en aluminio. **(IT) Attenzione:** Istruzioni di montaggio per barre in alluminio. **(NL) Attentie:** Handleiding voor dakdragers gemaakt van aluminium.

1

(D) EINSCHIEBEN
(GB) INSERT
(F) ENFILER
(E) CUBRIR
(IT) INSERIRE
(NL) BEVESTIG

3

(D) DÜBEL
(GB) INSERT
(F) TAMPON
(E) CUÑA
(IT) INSERTO
(NL) INVOEGSTUK

(D) SIEHE DIE BEILIEGENDE ANWENDUNGSTABELLE
(GB) SEE THE ATTACHED APPLICATION TABLE
(F) VOIR LE TABLEAU D'APPLICATION ATTACHE'
(E) CONSULTE LA TABLA DE APLICABILIDAD ADJUNTA
(IT) VEDERE LA TABELLA APPLICABILITA' ALLEGATA
(NL) KIJK IN DE BIJGEOVOEGDE APPLICATIETABEL

SI/YES/YA/OUI | **NO/NO/NEIN/NON**

(D) ENTFERNEN
(GB) REMOVE
(F) ENLEVER
(E) ELIMINAR
(IT) TOGLIERE
(NL) VERWIJDEREN

4

(D) BIEGEN
(GB) BEND
(F) PLIER
(E) DOBLAR
(IT) PIEGARE
(NL) BUIGEN

(D) EINSCHIEBEN
(GB) INSERT
(F) ENFILER
(E) CUBRIR
(IT) INSERIRE
(NL) BEVESTIG

(x4)

2

(D) SIEHE DIE BEILIEGENDE ANWENDUNGSTABELLE UM DEN RICHTIGEN KUPPLER ZU WÄHLEN
(GB) SEE THE ATTACHED APPLICATION TABLE FOR THE COUPLER CHOICE
(F) VOIR LE TABLEAU D'APPLICATION ATTACHE' AU FIN DE CHOISIR LE TIRANT LE PLUS CORRECT
(E) CONSULTE LA TABLA DE APLICABILIDAD ADJUNTA PARA SELECCIONAR LOS TIRANTE APROPRIADO
(IT) VEDERE LA TABELLA APPLICABILITA' ALLEGATA PER LA SCELTA DEL TIRANTE
(NL) KIJK IN DE BIJGEOVOEGDE APPLICATIETABEL VOOR DE JUISTE KEUZE MONTAGEBEUGELS

(D) ABSCHRAUBEN
(GB) UNSCREW
(F) DEVISSER
(E) AFLOJAR
(IT) SVITARE
(NL) OPENSCHROEVEN

(D) ZUSAMMENBAU DER KOPPLER 2
(GB) HOW TO ASSEMBLE COUPLER 2
(F) MONTAGE TIRANT 2
(E) COMO MONTAR LOS TIRANTE 2
(IT) MONTAGGIO TIRANTE 2
(NL) MONTAGE VAN DE TREKSTANG 2

(D) ERSETZEN
(GB) TO REPLACE
(F) REMPLACER
(E) APRETAR
(IT) SOSTITUIRE
(NL) VERVANGEN

(D) FESTSCHRAUBEN
(GB) TO SCREW
(F) VISSER
(E) APRETAR
(IT) AVVITARE
(NL) VASTSCHROEVEN

(x4)

5

(D) EINSCHIEBEN
(GB) INSERT
(F) ENFILER
(E) CUBRIR
(IT) INSERIRE
(NL) BEVESTIG

(x4)

6

(D) EINSCHIEBEN
(GB) INSERT
(F) ENFILER
(E) CUBRIR
(IT) INSERIRE
(NL) BEVESTIG

(x4)

7

(D) EINSCHIEBEN
(GB) INSERT
(F) ENFILER
(E) CUBRIR
(IT) INSERIRE
(NL) BEVESTIG

(x4)

8

(D) VORDERE
(GB) FRONT
(F) AVANT
(E) DELANTERO
(IT) ANTERIORE
(NL) VOORSTE G.

(D) HINTERE
(GB) REAR
(F) ARRIERE
(E) TRASERO
(IT) POSTERIORE
(NL) ACHTERSTE G.

RAILS

9

OPTIMUM
70 cm

10

(D) LASTENTRÄGER AUF DEM DACH ZENTRIEREN
(GB) CENTRE THE UNIVERSAL BAR CARRIER ON THE ROOF
(F) CENTRER LA BARRE DE TOIT SUR LE TOIT
(E) CENTRAR EL PORTAEQUIPAJES SOBRE EL TECHO
(IT) CENTRARE IL P. TUTTO SUL TETTO
(NL) PLAATS DE UNIVERSELE DRAGER IN HET MIDDEN VAN HET DAK

11

(D) FESTSCHRAUBEN
(GB) TO SCREW
(F) VISSER
(E) APRETAR
(IT) AVVITARE
(NL) VASTSCHROEVEN

4 Nm

(x4)

12

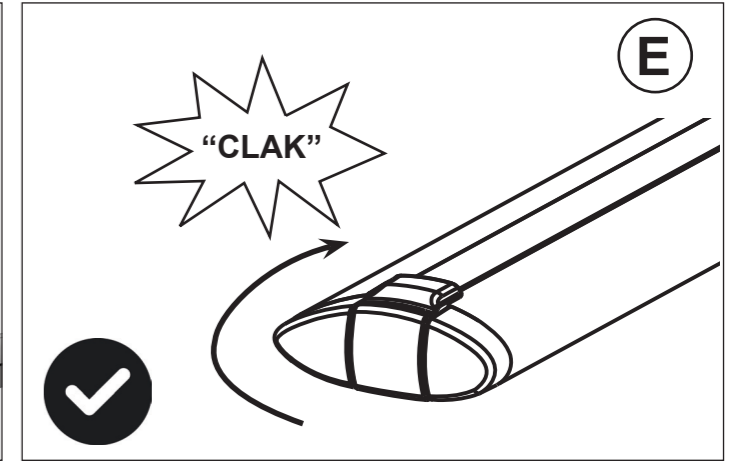
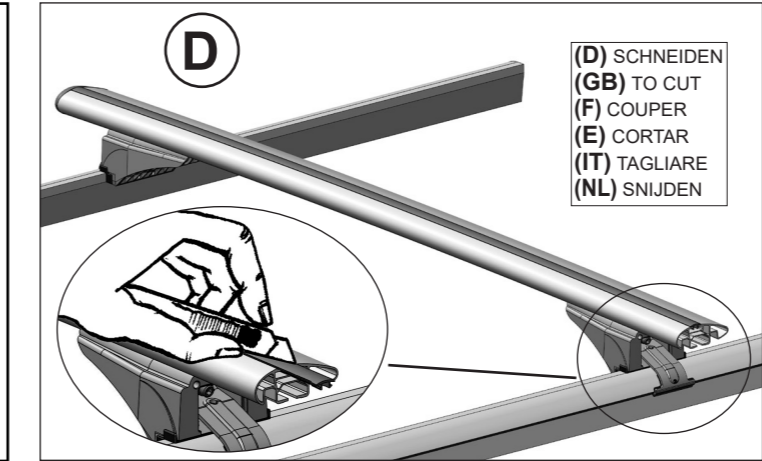
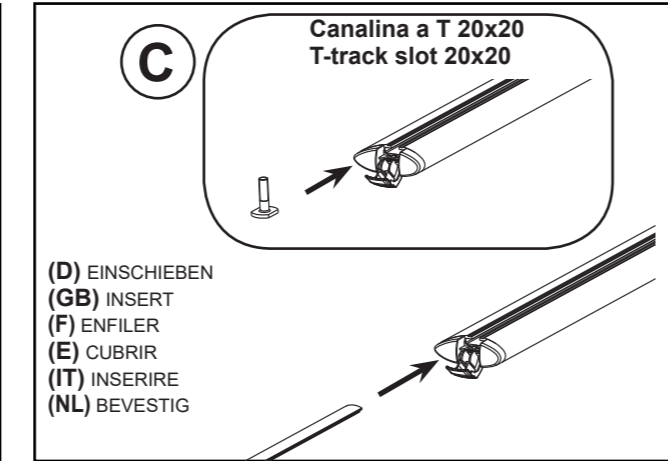
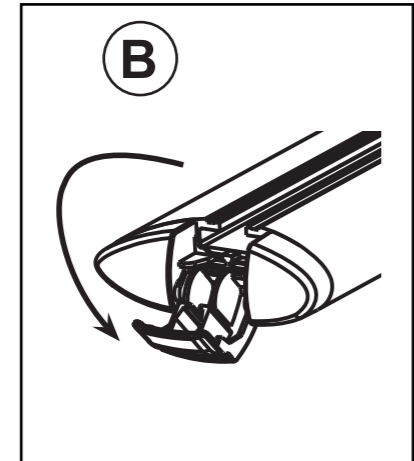
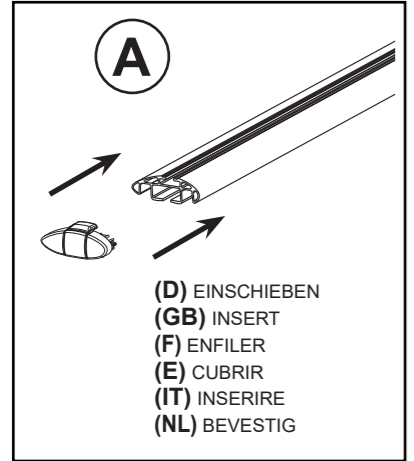

13

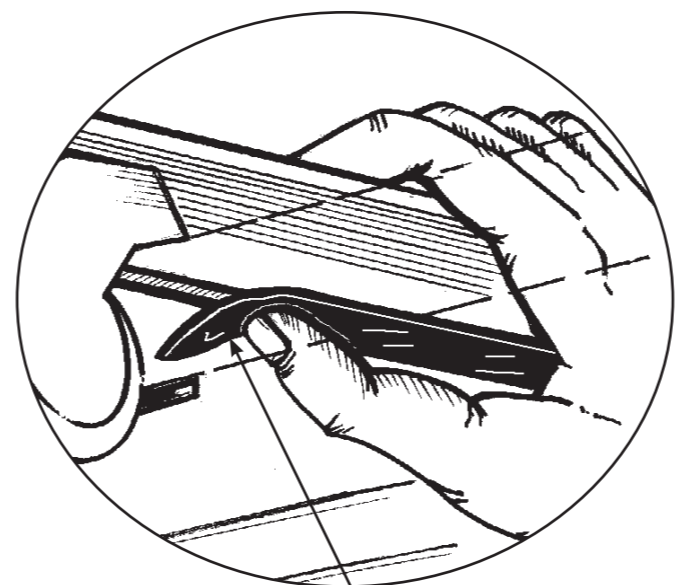
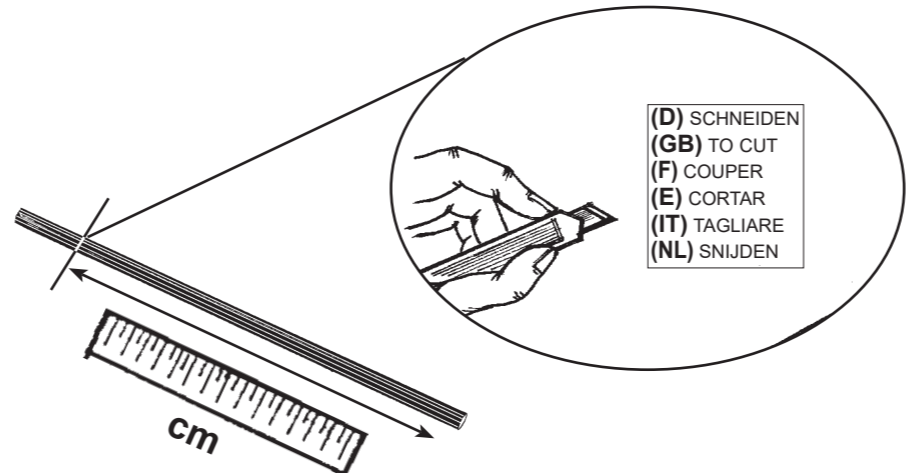
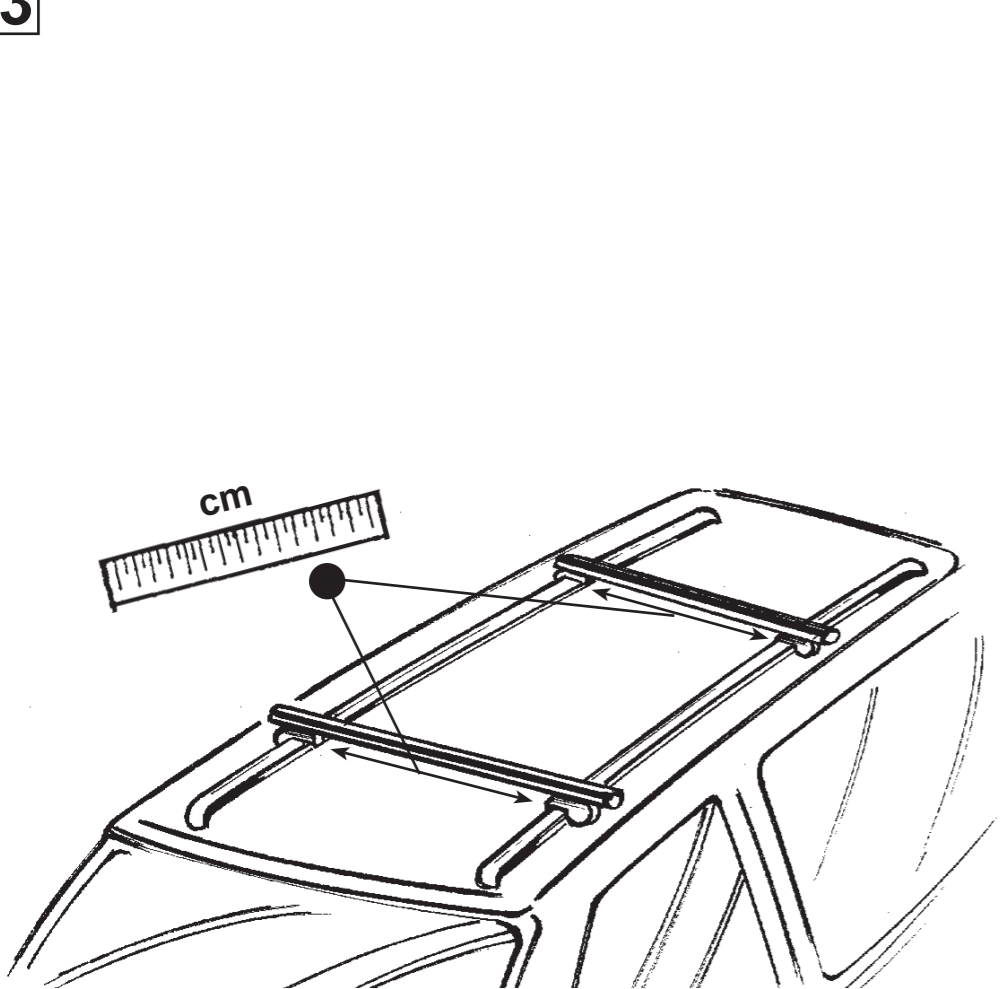

(D) EINSCHIEBEN
(GB) INSERT
(F) ENFILER
(E) CUBRIR
(IT) INSERIRE
(NL) BEVESTIG

(x2)

14

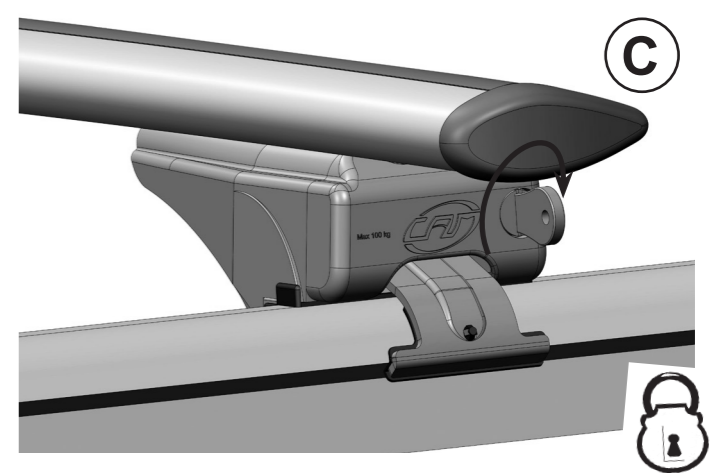
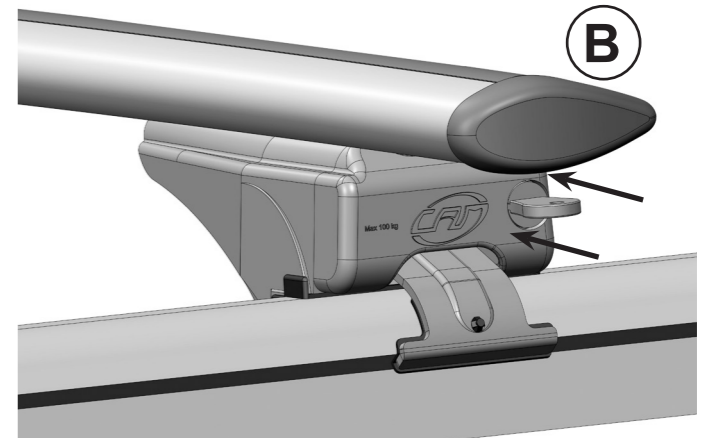
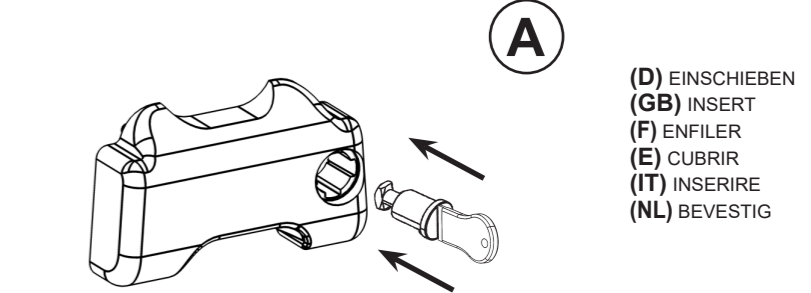

(x4)

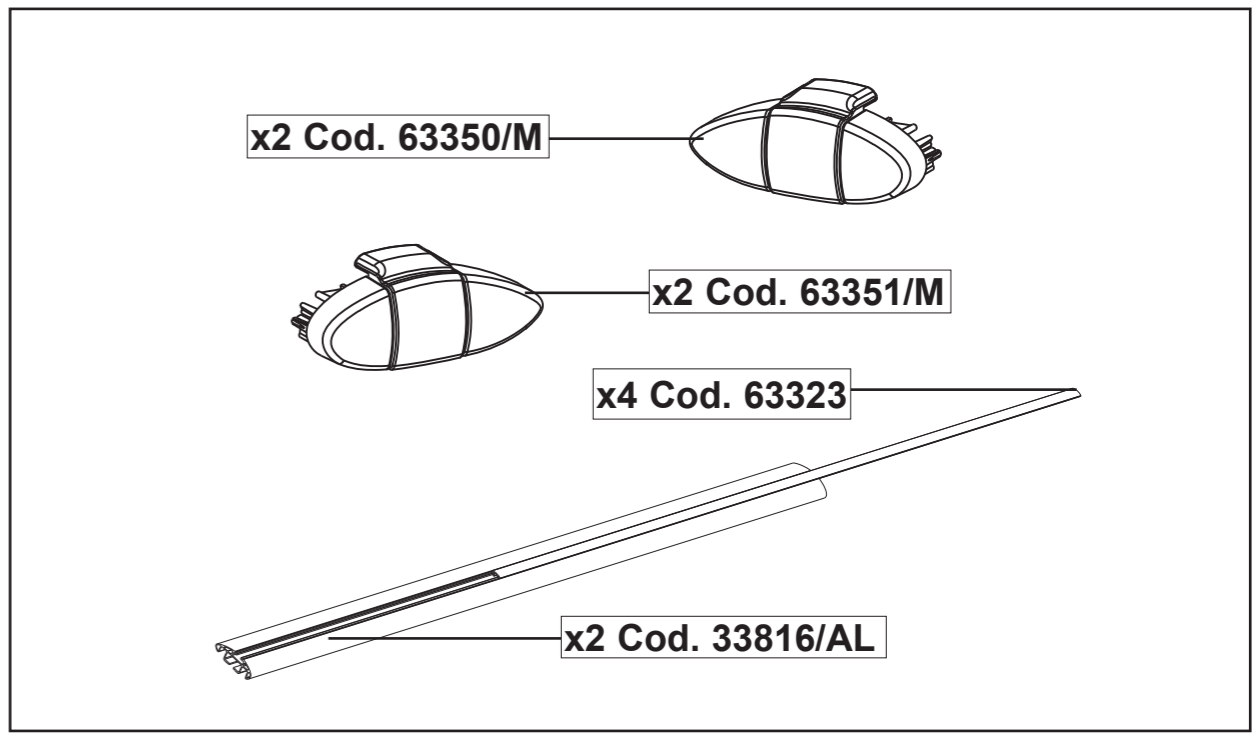
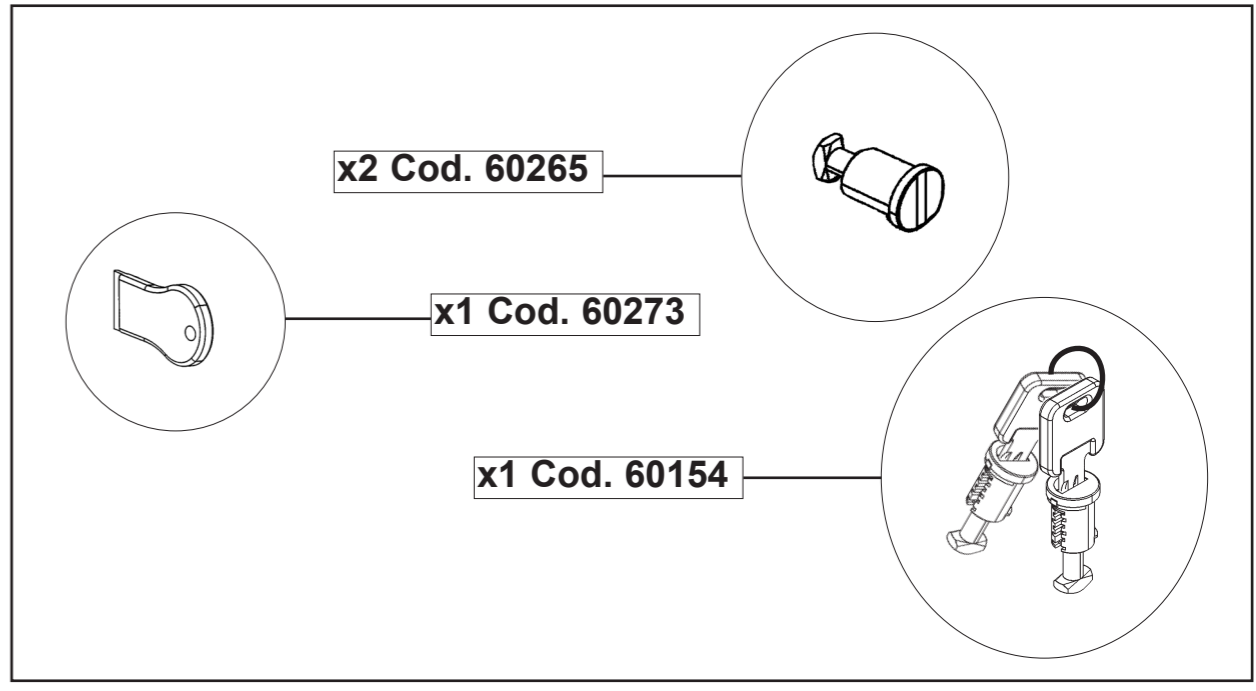
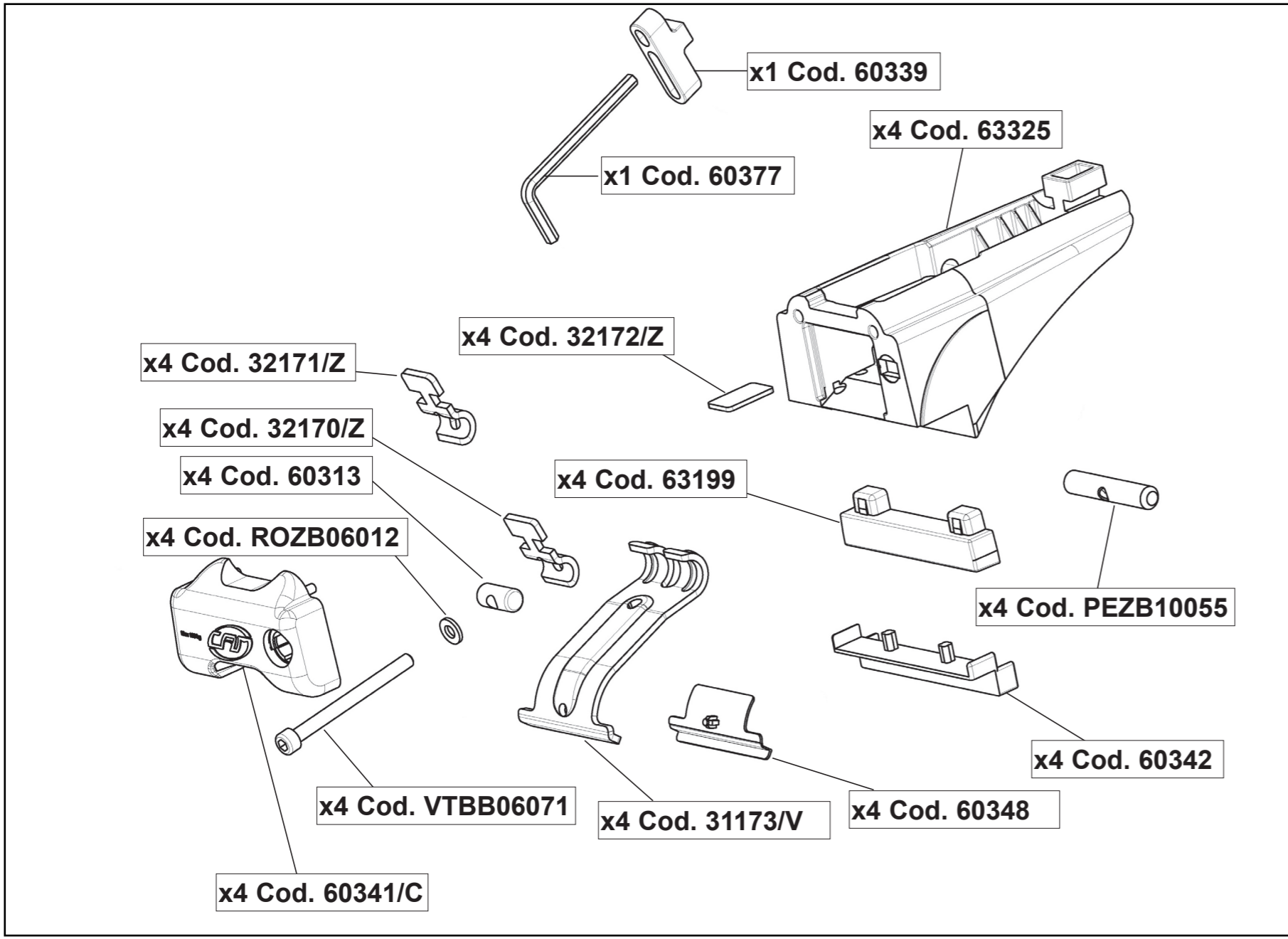

(IT) SI RACCOMANDA DI NON SUPERARE IL CARICO MASSIMO SUL TETTO AUTORIZZATO DAL COSTRUTTORE DEL VEICOLO.
(GB) IT IS RECOMMENDED NOT EXCEED THE MAXIMUM ROOF LOAD AUTHORIZED BY THE VEHICLE MANUFACTURER.
(E) SE RECOMIENDA NO SUPERAR LA CARGA MÁXIMA DEL TECHO AUTORIZADA POR EL FABRICANTE DEL VEHÍCULO.
(D) ES WIRD EMPFOHLEN, DIE VOM FAHRZEUGHERSTELLER GENEHMIGTE MAXIMALE DACHLAST NICHT ZU ÜBERSCHREITEN.
(F) IL EST RECOMMANDÉ DE NE PAS DÉPASSER LA CHARGE MAXIMALE SUR LE TOIT AUTORISÉE PAR LE CONSTRUCTEUR DU VÉHICULE.
(NL) HET WORDT AANBEVOLEN DE DOOR DE VOERTUIGFABRIKANT TOEGESTANE MAXIMALE DAKBELASTING NIET TE OVERSCHRIJDEN.

(IT) VEDERE LA TABELLA APPLICABILITA' ALLEGATA
 (GB) SEE THE ATTACHED APPLICATION TABLE
 (E) CONSULTE LA TABLA DE APPLICABILIDAD ADJUNTA
 (D) SIEHE DIE BEILIEGENDE ANWENDUNGSTABELLE
 (F) VOIR LE TABLEAU D'APPLICATION ATTACHE'
 (NL) KIJK IN DE BIJGEVOEGDE APPLICATIETABEL

MAX
... kg
... lb

+

4.5 kg
9.9 lb

=

..... kg
..... lb

?

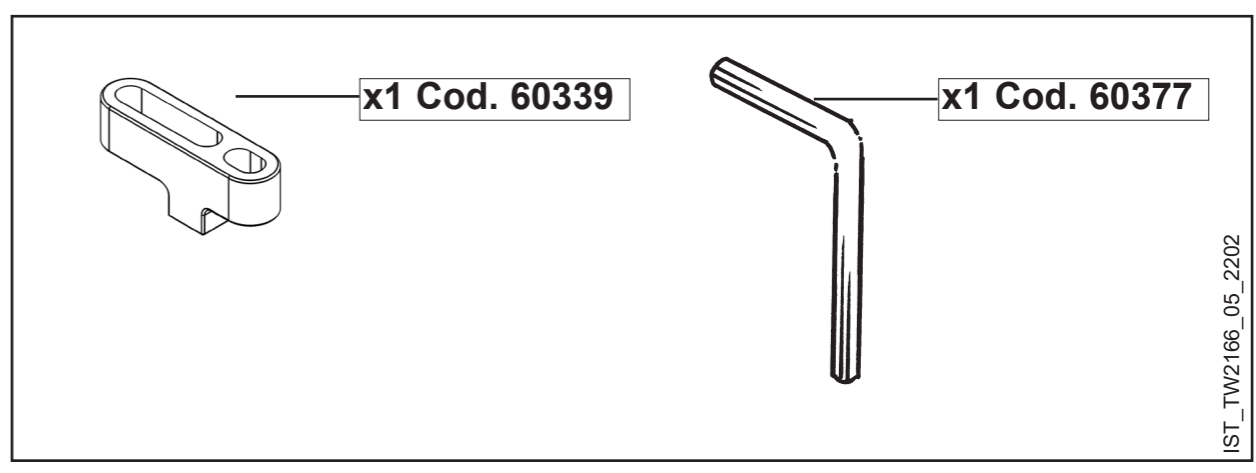

TWINNY F 01 APPLICATION LIST

| (IT) INSERTO (GB) INSERT (E) CUNA (D) DUBEL (F) TAMPON (NL) INVOEGSTUK (H) BESZURAS (PL) WKŁADKA (SLO) VLOŽKA (HR) UMETAK | (IT) TIRANTE (GB) COUPLER (E) TIRANTE (D) KOPPLER (F) TIRANT (NL) TREKSTANG (H) RÓGZÍTO BETÉT (PL) ŁAPKA (SLO) SPOJ (HR) ZAKAVKA | (IT) PORTATA MAX (GB) MAX LOAD (E) CARGA MÁXIMA (D) MAXIMALE (F) CHARGE MAXIMALE (NL) BELASTBAAR (H) TERHERBIRASA (PL) ŁADOWNOSC (SLO) VRHUNSKA (HR) NOSIVOST |
|--|---|--|
| (IT) MODELLI AUTO (GB) CARS (E) COCHES (D) WAGEN (F) VOITURES (NL) AUTO (P) MODELO AUTO (H) AUTO TIPIJS (PL) MODELE SAMOCHODÓW (SLO) MODEL AVTOMOBILOV (HR) MODELI AUTA | | |
| ALFA ROMEO 159 SW (06>11) Rail aperti/Open rails/Mit Reling/Railing | SIYESYA/OUI | 75 Kg |
| AUDI A3 Sportback 5P (04>08) Rail chiusi/Integrated rails/Geschlossener Reling/Railing intègrés | SIYESYA/OUI | 75 Kg |
| AUDI A3 Sportback 5P (08>12) Rail chiusi/Integrated rails/Geschlossener Reling/Railing intègrés | SIYESYA/OUI | 75 Kg |
| AUDI A3 Sportback 5P (12>20) Rail chiusi/Integrated rails/Geschlossener Reling/Railing intègrés | SIYESYA/OUI | 75 Kg |
| AUDI A4 Allroad SW (09>16) Rail aperti/Open rails/Mit Reling/Railing | SIYESYA/OUI | 90 Kg |
| AUDI A4 Allroad SW (16>) Rail aperti/Open rails/Mit Reling/Railing | SIYESYA/OUI | 90 Kg |
| AUDI A4 Avant SW (08>15) Rail chiusi/Integrated rails/Geschlossener Reling/Railing intègrés | SIYESYA/OUI | 75 Kg |
| AUDI A4 Avant SW (15>) Rail chiusi/Integrated rails/Geschlossener Reling/Railing intègrés | SIYESYA/OUI | 75 Kg |
| AUDI A6 Allroad SW (12>18) Rail aperti/Open rails/Mit Reling/Railing | SIYESYA/OUI | 90 Kg |
| AUDI A6 Avant SW (05>11) Rail chiusi/Integrated rails/Geschlossener Reling/Railing intègrés | SIYESYA/OUI | 75 Kg |
| AUDI A6 Avant SW (11>18) Rail chiusi/Integrated rails/Geschlossener Reling/Railing intègrés | SIYESYA/OUI | 75 Kg |
| AUDI A6 Avant SW (18>) Rail chiusi/Integrated rails/Geschlossener Reling/Railing intègrés | SIYESYA/OUI | 75 Kg |
| AUDI Q3 SUV (11>18) Rail chiusi/Integrated rails/Geschlossener Reling/Railing intègrés | SIYESYA/OUI | 75 Kg |
| AUDI Q3 SUV (18>) Rail chiusi/Integrated rails/Geschlossener Reling/Railing intègrés | SIYESYA/OUI | 75 Kg |
| AUDI Q5 SUV (08>16) Rail chiusi/Integrated rails/Geschlossener Reling/Railing intègrés | SIYESYA/OUI | 75 Kg |
| AUDI Q5 SUV (17>) Rail chiusi/Integrated rails/Geschlossener Reling/Railing intègrés | SIYESYA/OUI | 75 Kg |
| AUDI Q7 SUV (06>09) Rail chiusi/Integrated rails/Geschlossener Reling/Railing intègrés | SIYESYA/OUI | 75 Kg |
| AUDI Q7 SUV (09>15) Rail chiusi/Integrated rails/Geschlossener Reling/Railing intègrés | SIYESYA/OUI | 75 Kg |
| BMW Serie 2 Active Tourer MPV (14>) Rail chiusi/Integrated rails/Geschlossener Reling/Railing intègrés | SIYESYA/OUI | 75 Kg |
| BMW Serie 2 Gran Tourer MPV (15>) Rail chiusi/Integrated rails/Geschlossener Reling/Railing intègrés | SIYESYA/OUI | 75 Kg |
| BMW Serie 3 Touring SW (10>12) Rail chiusi/Integrated rails/Geschlossener Reling/Railing intègrés | SIYESYA/OUI | 75 Kg |
| BMW Serie 3 Touring SW (12>19) Rail chiusi/Integrated rails/Geschlossener Reling/Railing intègrés | SIYESYA/OUI | 75 Kg |
| BMW Serie 5 Touring SW (10>17) Rail chiusi/Integrated rails/Geschlossener Reling/Railing intègrés | SIYESYA/OUI | 60 Kg |
| BMW X1 SUV (09>15) Rail chiusi/Integrated rails/Geschlossener Reling/Railing intègrés | SIYESYA/OUI | 75 Kg |
| BMW X1 SUV (15>) Rail chiusi/Integrated rails/Geschlossener Reling/Railing intègrés | SIYESYA/OUI | 75 Kg |
| BMW X3 SUV (10>17) Rail chiusi/Integrated rails/Geschlossener Reling/Railing intègrés | SIYESYA/OUI | 75 Kg |
| BMW X5 SUV (07>13) Rail chiusi/Integrated rails/Geschlossener Reling/Railing intègrés | SIYESYA/OUI | 75 Kg |
| CADILLAC SRX SUV (10>16) Rail aperti/Open rails/Mit Reling/Railing | SIYESYA/OUI | 75 Kg |
| CHEVROLET / DAEWOO Captiva SUV (06>15) Rail aperti/Open rails/Mit Reling/Railing | SIYESYA/OUI | 90 Kg |
| CHEVROLET / DAEWOO Cruze SW (08>16) Rail aperti/Open rails/Mit Reling/Railing | NO/NO/NEIN/NON | 90 Kg |
| CITROËN C3 Picasso MPV (09>17) Rail aperti/Open rails/Mit Reling/Railing | SIYESYA/OUI | 60 Kg |
| CITROËN C4 Aircross SUV (12>17) Rail chiusi/Integrated rails/Geschlossener Reling/Railing intègrés | SIYESYA/OUI | 75 Kg |
| CITROËN C5 II Tourer SW (08>17) Rail aperti/Open rails/Mit Reling/Railing | NO/NO/NEIN/NON | 75 Kg |
| CUPRA Ateca SUV (18>) Rail aperti/Open rails/Mit Reling/Railing | SIYESYA/OUI | 75 Kg |
| DACIA Logan II MCV SW (13>21) Rail aperti/Open rails/Mit Reling/Railing | NO/NO/NEIN/NON | 75 Kg |
| DACIA Sandero Stepway II SUV (13>21) Rail aperti/Open rails/Mit Reling/Railing | NO/NO/NEIN/NON | 75 Kg |
| DR DR 5 SUV (07>18) Rail aperti/Open rails/Mit Reling/Railing | SIYESYA/OUI | 75 Kg |
| FIAT 500X SUV (15>) Rail chiusi/Integrated rails/Geschlossener Reling/Railing intègrés | NO/NO/NEIN/NON | 75 Kg |
| FIAT Panda II 5P (03>12) Rail aperti/Open rails/Mit Reling/Railing | NO/NO/NEIN/NON | 50 Kg |
| FIAT Panda III 5P (12>) Rail chiusi/Integrated rails/Geschlossener Reling/Railing intègrés | SIYESYA/OUI | 75 Kg |
| FIAT Panda III Cross 5P (14>) Rail aperti/Open rails/Mit Reling/Railing | SIYESYA/OUI | 55 Kg |
| FIAT Tipo II SW (16>) Rail chiusi/Integrated rails/Geschlossener Reling/Railing intègrés | NO/NO/NEIN/NON | 75 Kg |
| FORD Edge SUV (16>) Rail chiusi/Integrated rails/Geschlossener Reling/Railing intègrés | SIYESYA/OUI | 75 Kg |
| FORD Fiesta VII Active SUV (17>) Rail chiusi/Integrated rails/Geschlossener Reling/Railing intègrés | NO/NO/NEIN/NON | 75 Kg |
| FORD Focus III SW (11>18) Rail chiusi (no rail in plastica)/Integrated rails (no plastic rails)/ Geschlossener Reling (keine Kunststoff Reling)/Railing intègrés (ne pas de rails en matière plastique) | SIYESYA/OUI | 75 Kg |
| FORD Focus IV SW (18>) Rail chiusi/Integrated rails/Geschlossener Reling/Railing intègrés | SIYESYA/OUI | 75 Kg |
| FORD Focus IV Active 5P (19>) Rail chiusi/Integrated rails/Geschlossener Reling/Railing intègrés | NO/NO/NEIN/NON | 75 Kg |
| FORD Mondeo V SW (15>) Rail chiusi/Integrated rails/Geschlossener Reling/Railing intègrés | SIYESYA/OUI | 75 Kg |
| HONDA Civic IX Tourer SW (13>17) Rail chiusi/Integrated rails/Geschlossener Reling/Railing intègrés | SIYESYA/OUI | 75 Kg |
| HYUNDAI ix35 SUV (10>15) Rail chiusi/Integrated rails/Geschlossener Reling/Railing intègrés | SIYESYA/OUI | 60 Kg |
| HYUNDAI Kona SUV (17>) Rail chiusi/Integrated rails/Geschlossener Reling/Railing intègrés | SIYESYA/OUI | 60 Kg |
| HYUNDAI Tucson III SUV (15>18) Rail chiusi/Integrated rails/Geschlossener Reling/Railing intègrés | SIYESYA/OUI | 75 Kg |
| KIA Carens MPV (13>18) Rail chiusi/Integrated rails/Geschlossener Reling/Railing intègrés | SIYESYA/OUI | 75 Kg |
| KIA Cee'd II Sporty Wagon SW (12>18) Rail chiusi/Integrated rails/Geschlossener Reling/Railing intègrés | SIYESYA/OUI | 60 Kg |
| KIA Niro SUV (16>) Rail chiusi/Integrated rails/Geschlossener Reling/Railing intègrés | SIYESYA/OUI | 75 Kg |
| KIA Sportage III SUV (10>15) Rail chiusi/Integrated rails/Geschlossener Reling/Railing intègrés | SIYESYA/OUI | 60 Kg |
| KIA Sportage IV SUV (16>21) Rail chiusi/Integrated rails/Geschlossener Reling/Railing intègrés | SIYESYA/OUI | 75 Kg |
| MERCEDES Classe C SW (07>14) Rail aperti/Open rails/Mit Reling/Railing | SIYESYA/OUI | 75 Kg |
| MERCEDES Classe C SW (14>21) Rail chiusi/Integrated rails/Geschlossener Reling/Railing intègrés | SIYESYA/OUI | 75 Kg |
| MERCEDES Classe E SW (09>16) Rail aperti/Open rails/Mit Reling/Railing | SIYESYA/OUI | 90 Kg |
| MERCEDES Classe M SUV (11>15) Rail aperti/Open rails/Mit Reling/Railing | SIYESYA/OUI | 90 Kg |
| MERCEDES GLA SUV (13>20) Rail chiusi/Integrated rails/Geschlossener Reling/Railing intègrés | SIYESYA/OUI | 75 Kg |
| MERCEDES GLC SUV (15>) Rail chiusi/Integrated rails/Geschlossener Reling/Railing intègrés | SIYESYA/OUI | 75 Kg |
| MERCEDES GLE SUV (15>18) Rail aperti/Open rails/Mit Reling/Railing | SIYESYA/OUI | 90 Kg |
| MINI Countryman 5P (10>16) Rail chiusi/Integrated rails/Geschlossener Reling/Railing intègrés | SIYESYA/OUI | 60 Kg |
| MINI Countryman 5P (17>) Rail aperti/Open rails/Mit Reling/Railing | SIYESYA/OUI | 90 Kg |
| MITSUBISHI ASX SUV (10>) Rail chiusi/Integrated rails/Geschlossener Reling/Railing intègrés | SIYESYA/OUI | 75 Kg |
| MITSUBISHI Outlander III SUV (12>) Rail chiusi/Integrated rails/Geschlossener Reling/Railing intègrés | SIYESYA/OUI | 75 Kg |
| NISSAN Qashqai II SUV (13>21) Rail aperti/Open rails/Mit Reling/Railing | SIYESYA/OUI | 90 Kg |
| NISSAN X-Trail III SUV (14>) Rail aperti/Open rails/Mit Reling/Railing | SIYESYA/OUI | 90 Kg |
| OPEL Astra H SW (04>10) Rail chiusi/Integrated rails/Geschlossener Reling/Railing intègrés | SIYESYA/OUI | 75 Kg |
| OPEL Astra J Sport Tourer SW (11>15) Rail chiusi/Integrated rails/Geschlossener Reling/Railing intègrés | SIYESYA/OUI | 75 Kg |
| OPEL Insignia A Sports Tourer SW (09>17) Rail chiusi/Integrated rails/Geschlossener Reling/Railing intègrés | SIYESYA/OUI | 75 Kg |
| OPEL Mokka A SUV (12>19) Rail chiusi/Integrated rails/Geschlossener Reling/Railing intègrés | SIYESYA/OUI | 75 Kg |
| OPEL Mokka X SUV (16>19) Rail chiusi/Integrated rails/Geschlossener Reling/Railing intègrés | SIYESYA/OUI | 75 Kg |
| OPEL Vectra C SW (03>05) Rail chiusi/Integrated rails/Geschlossener Reling/Railing intègrés | SIYESYA/OUI | 75 Kg |
| OPEL Vectra C SW (06>08) Rail chiusi/Integrated rails/Geschlossener Reling/Railing intègrés | SIYESYA/OUI | 75 Kg |
| OPEL Zafira B MPV (05>15) Rail chiusi/Integrated rails/Geschlossener Reling/Railing intègrés | SIYESYA/OUI | 75 Kg |

TWINNY F 01 APPLICATION LIST

| (IT) MODELLI AUTO (GB) CARS (E) COCHES (D) WAGEN (F) VOITURES (NL) AUTO (P) MODELO AUTO (H) AUTO TIPIJS (PL) MODELE SAMOCHODÓW (SLO) MODEL AVTOMOBILŌV (HR) MODELI AUTA | (IT) INSERTO (GB) INSERT (E) CUNA (D) DÜBEL (F) TAMPON (NL) INVOEGSTUK (H) BESZURÁS (PL) WKŁADKA (SLO) VLOŽKA (HR) UMETAK | (IT) TIRANTE (GB) COUPLER (E) TIRANTE (D) KOPPLER (F) TIRANT (NL) TREKSTANG (H) RÖGZÍTŐ BETÉT (PL) ŁAPKA (SLO) SPOJ (HR) ZAKAČKA | (IT) PORTATA MAX (GB) MAX LOAD (E) CARGA MÁXIMA (D) MAXIMALE (F) CHARGE MAXIMALE (NL) BELASTIBAAR (H) TERHERBIÁRA (PL) ŁADOWNOŚĆ (SLO) VRHUNSKA NOSILNOST (HR) NOSIVOST |
|---|---|--|---|
| OPEL Zafira C MPV (11>19) Rail chiusi/Integrated rails/Geschlossener Reling/Railing intègrés | SIYES/YA/OU | 1 | 75 Kg |
| PEUGEOT 3008 II MPV (16>) Rail chiusi/Integrated rails/Geschlossener Reling/Railing intègrés | SIYES/YA/OU | 2 | 75 Kg |
| PEUGEOT 308 II SW (14>21) Rail chiusi/Integrated rails/Geschlossener Reling/Railing intègrés | SIYES/YA/OU | 1 | 75 Kg |
| PEUGEOT 5008 II MPV (17>) Rail chiusi/Integrated rails/Geschlossener Reling/Railing intègrés | SIYES/YA/OU | 2 | 75 Kg |
| PEUGEOT 508 I SW (11>18) Rail chiusi/Integrated rails/Geschlossener Reling/Railing intègrés | SIYES/YA/OU | 2 | 75 Kg |
| RENAULT Clio IV Sporter / Grandtour SW (13>20) Rail aperti/Open rails/Mit Reling/Railing | NON/NO/NE/IN/NO | 1 | 75 Kg |
| RENAULT Grand Scenic IV MPV (16>) 7 posti/rail chiusi/7 seats/integrated rails/7 Sitzer/geschlossener Reling/7 places/railing intègrés | NON/NO/NE/IN/NO | 1 | 75 Kg |
| RENAULT Kadjar SUV (15>) Rail chiusi/Integrated rails/Geschlossener Reling/Railing intègrés | SIYES/YA/OU | 1 | 75 Kg |
| RENAULT Koleos II SUV (17>) Rail chiusi/Integrated rails/Geschlossener Reling/Railing intègrés | SIYES/YA/OU | 1 | 75 Kg |
| RENAULT Megane III Sportour / Grandtour SW (09>16) Rail aperti/Open rails/Mit Reling/Railing | SIYES/YA/OU | 2 | 75 Kg |
| RENAULT Megane IV Sporter SW (16>) Rail chiusi/Integrated rails/Geschlossener Reling/Railing intègrés | NON/NO/NE/IN/NO | 1 | 75 Kg |
| RENAULT Talisman Sporter SW (16>) Rail chiusi/Integrated rails/Geschlossener Reling/Railing intègrés | SIYES/YA/OU | 2 | 75 Kg |
| SEAT Alhambra II MPV (10>21) Rail aperti/Open rails/Mit Reling/Railing | SIYES/YA/OU | 1 | 90 Kg |
| SEAT Altea Freetrack MPV (07>15) Rail chiusi/Integrated rails/Geschlossener Reling/Railing intègrés | SIYES/YA/OU | 1 | 75 Kg |
| SEAT Altea XL MPV (06>15) Rail chiusi/Integrated rails/Geschlossener Reling/Railing intègrés | SIYES/YA/OU | 1 | 75 Kg |
| SEAT Arona SUV (17>) Rail aperti/Open rails/Mit Reling/Railing | SIYES/YA/OU | 1 | 75 Kg |
| SEAT Ateca SUV (16>) Rail aperti/Open rails/Mit Reling/Railing | SIYES/YA/OU | 2 | 75 Kg |
| SEAT Ibiza ST SW (10>17) Rail chiusi/Integrated rails/Geschlossener Reling/Railing intègrés | SIYES/YA/OU | 1 | 75 Kg |
| SEAT Leon III ST SW (13>20) Rail chiusi/Integrated rails/Geschlossener Reling/Railing intègrés | SIYES/YA/OU | 1 | 75 Kg |
| SEAT Leon III X-PERIENCE SW (15>20) Rail chiusi/Integrated rails/Geschlossener Reling/Railing intègrés | SIYES/YA/OU | 1 | 75 Kg |
| SEAT Terraco SUV (18>) Rail aperti/Open rails/Mit Reling/Railing | SIYES/YA/OU | 1 | 75 Kg |
| SKODA Kamiq SUV (19>) Rail aperti/Open rails/Mit Reling/Railing | SIYES/YA/OU | 2 | 75 Kg |
| SKODA Karoq SUV (17>) Rail aperti/Open rails/Mit Reling/Railing | SIYES/YA/OU | 1 | 75 Kg |
| SKODA Kodiaq SUV (17>) Rail aperti/Open rails/Mit Reling/Railing | NON/NO/NE/IN/NO | 2 | 75 Kg |
| SKODA Octavia IV SW (20>) Rail chiusi/Integrated rails/Geschlossener Reling/Railing intègrés | SIYES/YA/OU | 1 | 75 Kg |
| SKODA Superb III Wagon SW (15>) Rail aperti/Open rails/Mit Reling/Railing | SIYES/YA/OU | 1 | 90 Kg |
| SUZUKI Ignis III 5P (16>) Rail aperti/Open rails/Mit Reling/Railing | SIYES/YA/OU | 2 | 50 Kg |
| SUZUKI SX4 S-Cross 5P (13>21) Rail chiusi/Integrated rails/Geschlossener Reling/Railing intègrés | SIYES/YA/OU | 1 | 75 Kg |
| SUZUKI Vitara SUV (15>) Rail chiusi/Integrated rails/Geschlossener Reling/Railing intègrés | SIYES/YA/OU | 2 | 75 Kg |
| TOYOTA Auris Touring Sports SW (13>18) Rail chiusi/Integrated rails/Geschlossener Reling/Railing intègrés | SIYES/YA/OU | 1 | 75 Kg |
| VOLKSWAGEN Cross Polo V 5P (10>17) Rail aperti/Open rails/Mit Reling/Railing | SIYES/YA/OU | 1 | 90 Kg |
| VOLKSWAGEN Cross Up! 5P (14>19) Rail aperti/Open rails/Mit Reling/Railing | SIYES/YA/OU | 1 | 90 Kg |
| VOLKSWAGEN Golf Sportsvan MPV (14>20) Rail aperti/Open rails/Mit Reling/Railing | SIYES/YA/OU | 2 | 90 Kg |
| VOLKSWAGEN Golf VII Variant SW (13>20) Rail aperti/Open rails/Mit Reling/Railing | SIYES/YA/OU | 2 | 90 Kg |
| VOLKSWAGEN ID.4 SUV (20>) Rail chiusi/Integrated rails/Geschlossener Reling/Railing intègrés | SIYES/YA/OU | 1 | 75 Kg |
| VOLKSWAGEN Passat VIII Variant SW (14>) Rail chiusi/Integrated rails/Geschlossener Reling/Railing intègrés | SIYES/YA/OU | 1 | 75 Kg |
| VOLKSWAGEN T-Cross SUV (18>) Rail aperti/Open rails/Mit Reling/Railing | NON/NO/NE/IN/NO | 1 | 90 Kg |
| VOLKSWAGEN Tiguan I SUV (07>16) Rail aperti/Open rails/Mit Reling/Railing | SIYES/YA/OU | 2 | 90 Kg |
| VOLKSWAGEN Tiguan II SUV (16>) Rail aperti/Open rails/Mit Reling/Railing | SIYES/YA/OU | 1 | 90 Kg |
| VOLKSWAGEN Tiguan II SUV (16>) Rail aperti/Open rails/Mit Reling/Railing | SIYES/YA/OU | 1 | 90 Kg |
| VOLKSWAGEN Touran II MPV (15>) Rail aperti/Open rails/Mit Reling/Railing | SIYES/YA/OU | 1 | 90 Kg |
| VOLVO V40 II Cross Country SW (12>19) Rail aperti/Open rails/Mit Reling/Railing | SIYES/YA/OU | 2 | 75 Kg |
| VOLVO V50 SW (04>12) Rail aperti/Open rails/Mit Reling/Railing | NON/NO/NE/IN/NO | 1 | 75 Kg |
| VOLVO V60 I SW (10>18) Rail chiusi/Integrated rails/Geschlossener Reling/Railing intègrés | SIYES/YA/OU | 1 | 75 Kg |
| VOLVO V60 I Cross Country SW (16>18) Rail chiusi/Integrated rails/Geschlossener Reling/Railing intègrés | SIYES/YA/OU | 1 | 75 Kg |
| VOLVO V90 SW (16>) Rail chiusi/Integrated rails/Geschlossener Reling/Railing intègrés | SIYES/YA/OU | 1 | 90 Kg |
| VOLVO V90 Cross Country SW (16>) Rail chiusi/Integrated rails/Geschlossener Reling/Railing intègrés | SIYES/YA/OU | 1 | 90 Kg |
| VOLVO XC60 I SUV (10>17) Rail chiusi/Integrated rails/Geschlossener Reling/Railing intègrés | SIYES/YA/OU | 2 | 90 Kg |
| VOLVO XC60 II SUV (17>) Rail chiusi/Integrated rails/Geschlossener Reling/Railing intègrés | SIYES/YA/OU | 2 | 90 Kg |
| VOLVO XC90 II SUV (15>) Rail aperti/Open rails/Mit Reling/Railing | SIYES/YA/OU | 1 | 90 Kg |
| VOLVO XC90 II SUV (15>) Rail chiusi/Integrated rails/Geschlossener Reling/Railing intègrés | SIYES/YA/OU | 1 | 90 Kg |

I NORME D'USO DESTINATE A PORTATUTTO UNIVERSALI CONFORMI ALLE NORME DIN 75302.

- Effettuato il montaggio del portatutto, dopo alcuni chilometri ricontrrollare il fissaggio di tutte le viti.
- È necessario periodicamente, anche in funzione del fondo stradale, controllare i fissaggi di tutte le viti.
- Attenzione: la stabilità della vettura con portatutto montato può subire alterazioni nel comportamento su strada, nelle curve, nelle frenate ed in presenza di raffiche di vento. Si raccomanda quindi di guidare ed affrontare le curve a velocità moderata e di evitare brusche accelerate o frenate.
- Per motivi di sicurezza e di risparmio carburante è preferibile smontare il portatutto in caso di inutilizzo.
- **ATTENZIONE:** portata massima 90kg distribuiti uniformemente sulle due barre.

Attenzione: controllare sul libretto istruzioni della casa costruttrice la portata massima consentita dalla vostra vettura.

GB USING THE MULTI-PURPOSE RACK PROVIDED FOR BY THE DIN 75302 STANDARD.

- After rack assembly and few miles drive, ensure the bolts have been well tightened.
- Periodically check the tightening of all bolts, with particular reference to the effect of varying road surfaces.
- Caution: if the rack carries any load, vehicle stability may be affected, especially as regards roadholding in bends or in gusts and braking. Therefore, do not take bends at high speed and refrain from braking or accelerating sharply.
- When not in use, the rack should be taken off the car to improve safety and cut down on fuel consumption.
- It is not advisable to use a drive-through car wash with the rack still on top of the vehicle.
- **IMPORTANT:** maximum load 90kg to be distributed evenly between both bars.

Please keep within the load limits as provided for by your car manufacturer (refer to the user's manual of your vehicle).

F MODE D'EMPLOI DES PORTE-BAGAGES UNIVERSELS CONFORMES AUX NORMES DIN 75302.

Monter le porte-bagages: après quelques kilomètres, contrôler le serrage de toutes les vis.

Vérifier périodiquement le serrage de toutes les vis en tenant compte de l'état des routes.

Attention: la voiture équipée de porte-bagages peut subir des modifications dans la tenue de route, dans les virages, durant le freinage et en la présence de rafales de vent. Nous conseillons, par conséquent de conduire et d'aborder les virages à vitesse modérée et d'éviter de freiner et d'accélérer brusquement.

-Pour des raisons de sécurité et d'économie de carburant, il est préférable de démonter le porte-bagages en cas de non utilisation.

- **IMPORTANT:** capacité maximale de charge autorisée 90 kg, répartis uniformément sur les deux barres.

Se conformer aux instructions du constructeur de la voiture en ce qui concerne la charge maximale autorisée du véhicule.

E INSTRUCCIONES DE USO DE LOS PORTATODOS UNIVERSALES CONFORME A LAS NORMAS DIN 75301.

- Efectuado el montaje del portatodo, después de unos kilómetros, verificar que todos los tornillos sigan bien fijados.
- Seré necesario verificar, periódicamente y en función de tipo de carretera, las fijaciones de todos los tornillos.
- Atención: la estabilidad del automóvil con el montaje del portatodo puede sufrir algunos cambios: en curvas, mientras el frenado y si hay ráfagas de viento. Por eso, se recomienda conducir y girar a velocidad moderada y evitar los virajes bruscos, frenazos y acelerones.
- Por razones de seguridad y ahorro de combustible, se sugiere desmontar el portatodo cuando no sea necesario su uso.
- **IMPORTANTE:** peso máximo 90kg repartidos entre las dos barras.

Atención: verifiquen en el manual de instrucciones de su automóvil la capacidad máxima permitida.

D GEBRAUCHSANWEISUNG FÜR UNIVERSAL-DACHSKITRÄGER IM EINKLANG MIT DIN 75302.

- Fahren Sie nach Befestigung des Skiträgers einige Kilometer und überprüfen Sie dann nochmals alle Schrauben auf sichere Befestigung.
- Abhängig von der Ebenheit der Straßendecke sind sämtliche Schrauben regelmäßig nach zu kontrollieren.
- Achtung: Bei montiertem Dach-Skiträger kann sich das Fahrverhalten des Fahrzeugs ändern, insbesondere in Kurven, beim Bremsen und bei Windböen. Es empfiehlt sich daher, allgemein sowie speziell in Kurven mit mäßiger Geschwindigkeit zu fahren und abruptes Beschleunigen bzw. Bremsen zu vermeiden.
- Aus Sicherheitsgründen und zur Minderung des Kraftstoffverbrauchs sollten Sie den Dach-Skiträgers möglichst abmontieren wenn er nicht benötigt wird.
- **ACHTUNG:** (max 90 kg) In der Gebrauchsanweisung des Fabrikanten die Höchstbelastbarkeit Ihres Wagens nachschlagen.

NL GEBRUIKSNORMEN VAN DE BAGAGEDRAGERS IN OVEREENSTEMMING MET DIN 75302 NORMEN.

- Controleer, eens de bagagedrager volledig is gemonteerd, na enkele kilometers of alle schroeven goed vastzitten.
- Kijk achteraf en volgens de aard van de wegen die bereiden worden regelmatig na of alle schroeven wel degelijk vastzitten.
- Let op: na het monteren van de bagagedrager kan de stabiliteit van de wagen verschillen, vooral in bochten, bij het remmen en bij krachtige windstoten. Wij raden dan ook aan voorzichtig te rijden, bochten met verminderde snelheid te nemen, niet te bruusk te nemen en niet te snel op te trekken.
- Om veiligheidsredenen en om brandstof te besparen is het aangeraden de bagagedrager na gebruik weer van uw auto te halen.
- **BELANGRUK:** maximum belasting 90 kg gelijkmatig verdeeld over de hele bagagedrager de maximum belasting van uw wagen. Aangegeven door de autoconstructeur in de handleiding van de wagen, niet overschrijden.

